

DC Gear Motor

1.61.050.XXX

Type 1.61.050.XXX

V =	XXX	Characteristics*				max.	Terminal	Stages	Gear
		Rated current	Rated torque	Rated speed	No load speed	Torque*	resistance		ratio
		I_N / A	T_N / mNm	n_N / rpm	n_o / rpm	T_{max} / mNm	R_a / Ω		

12 V	440	3.300	400	460	535	560	0.7	2	6.3
	441	3.500	800	240	281	1120	0.7	2	12.0
	442	3.500	1500	116	136	2100	0.7	3	24.7
	443	3.600	2900	61	72	4060	0.7	3	46.7
	444	2.400	900	92	121	1260	1.9	3	24.7
	445	2.500	1800	48	64	2520	1.9	3	46.7
	446	2.500	3300	24	31	4620	1.9	4	96.5
	447	1.900	4000	14	16	5600	1.9	4	183.0
	448	1.500	5000	7.2	8	7000	1.9	5	377.0
	449	1.200	5000	4.0	4.2	7000	1.9	5	714.0

24 V	460	1.650	400	460	535	560	2.8	2	6.3
	461	1.750	800	240	281	1120	2.8	2	12.0
	462	1.750	1500	116	136	2100	2.8	3	24.7
	463	1.800	2900	61	72	4060	2.8	3	46.7
	464	1.200	900	92	121	1260	7.6	3	24.7
	465	1.250	1800	48	64	2520	7.6	3	46.7
	466	1.250	3300	24	31	4620	7.6	4	96.5
	467	0.950	4000	14	16	5600	7.6	4	183.0
	468	0.750	5000	7.2	8	7000	7.6	5	377.0
	469	0.600	5000	4.0	4.2	7000	7.6	5	714.0

Operational conditions

Temperature range	T	°C	-10 - +70
Axial force	F_A	N	30
Radial force, 5 mm from mounting surface	F_R	N	100

* at 25 °C

Design	
Weight	1200 g
Gear housing	Zinc die-cast
Commutator	Copper / 12-segments
RFI protection	-
Insulation class	Winding H, otherwise A
Protection class	IP40
Commutation	carbon brushes
Armature	skewed slot
Magnet system	Permanent magnets, 2-pole
Bearings	2 sintered bronze bearings
Motor housing	Steel, corrosion protected
Motor end shields	zinc die-cast on both sides
Spur gear	Metal and plastic gears
Axial play output shaft	0.05 - 0.5 mm

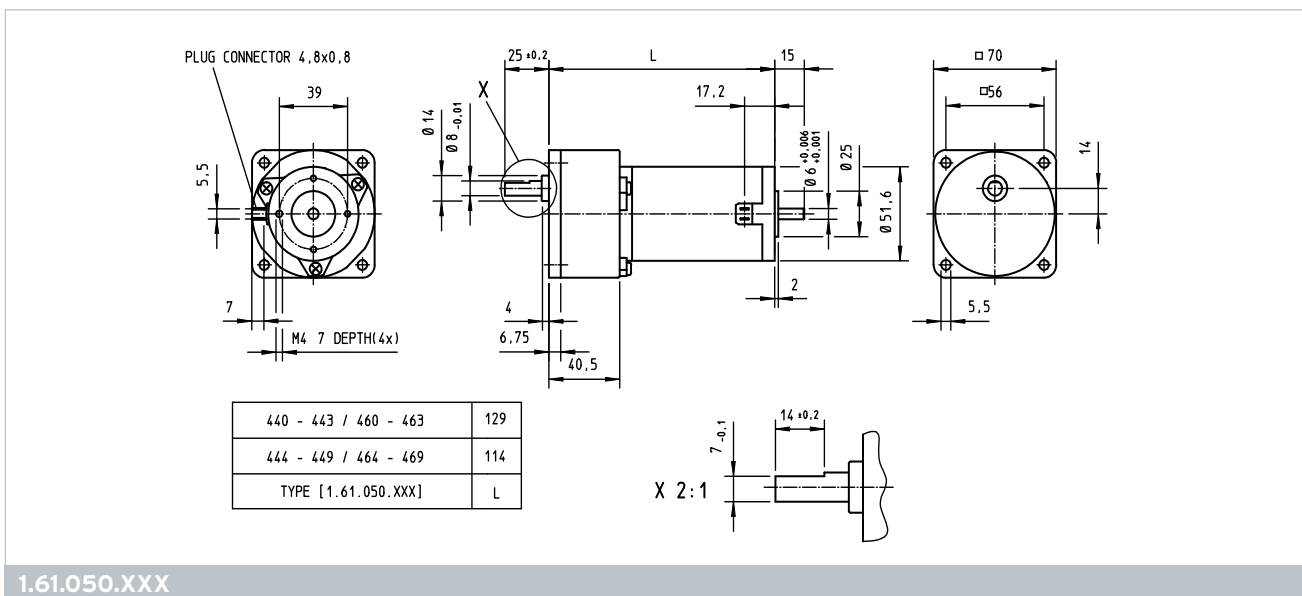

Customized versions

The following modifications are available upon request:

- ▶ Encoder possible
- ▶ Internal cokes and/or capacitors
- ▶ Speed adjustment by winding change
- ▶ Addition of wire harnesses
- ▶ Modification of shaft length
- ▶ Modification of shaft configuration (flat, groove, etc.)
- ▶ Assembly of gears, pinions, etc.
- ▶ Assembly of adapters and mounting plates