

# Extension Tube Actuator 1.61.098.1XX



## Product Description

The Extension Tube Actuator 1.61.098.1XX is an electro-mechanical actuation system designed to actuate the backrest, recline and legrest functions in First Class and Business Class seats in commercial aircraft but is of course not limited to that kind of applications. Performance is our driver. During the development we have designed an outstanding product in terms of

- Reliability
- Simplicity in operation and maintenance
- Light weight
- Low power consumption
- Low noise level
- Compact and modular design

The actuator family meets all applicable specifications from Airbus and Boeing.

We focused standardization and optimization of components to provide the best quality to price ratio and to help you to keep your products competitive. In addition the modular philosophy allows us to create highly flexible solutions fitting your special needs in only a short period of time.

For more complete information please refer to the technical details on the reverse side.

# Extension Tube Actuator 1.61.098.1XX

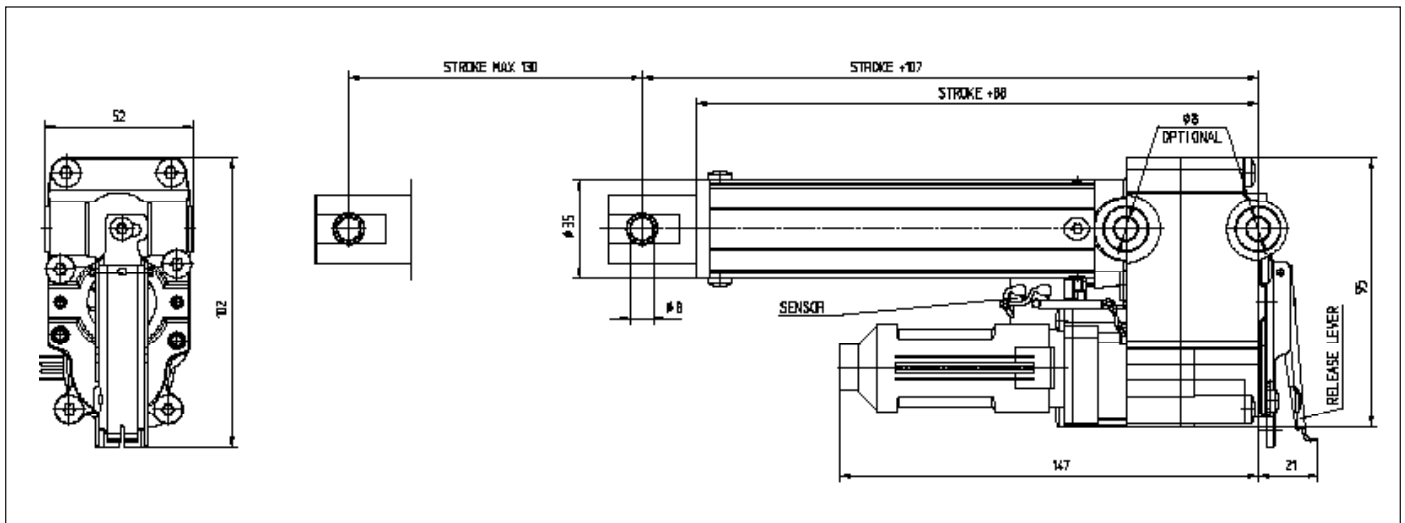

all dimensions in mm

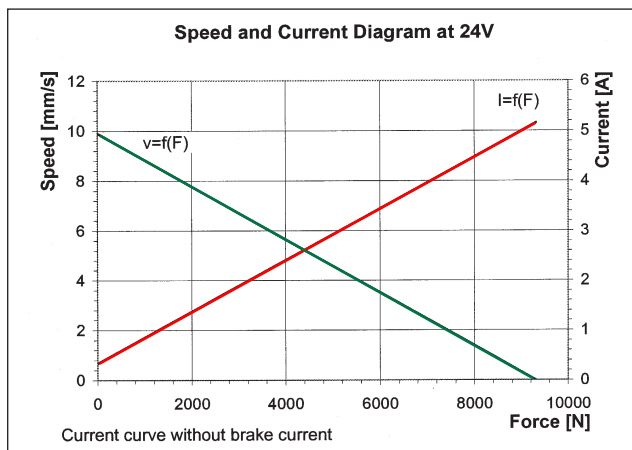

Nominal force: 33% of stall force  
50% of stall force for a short time possible

## Further design features

- position control feedback with integrated potentiometer
- gear train with integrated manual override function
- rare earth magnet motor
- brake with power saving functionality
- overload protection
- variable mechanical interfaces

## General Characteristics

Features	Metric measure	American/British measure
Operating voltage	24 V	24 V
Operating load	3100 N	700 lbf
Operating speed	5 mm/s	0.2 in/s
Operating current*	1.9 A	1.9 A
Peak operating load	4700 N	1060 lbf
Ultimate static load	16000 N	3600 lbf
Noise level**	50 dBA	50 dBA
Stroke capability	up to 130 mm	up to 5.1 in
Temperature range***	-40 °C to 70 °C	-40 F to 158 F
Weight	1.3 kg	2.86 lb

\* w/o Brake current

\*\* distance microphone 0.5 meter

\*\*\* Temperature capability, according test category RTCA/D0-160E, Section 4